

TECHNICAL DATA SHEET

BEAM WRAP ANCHORAGE

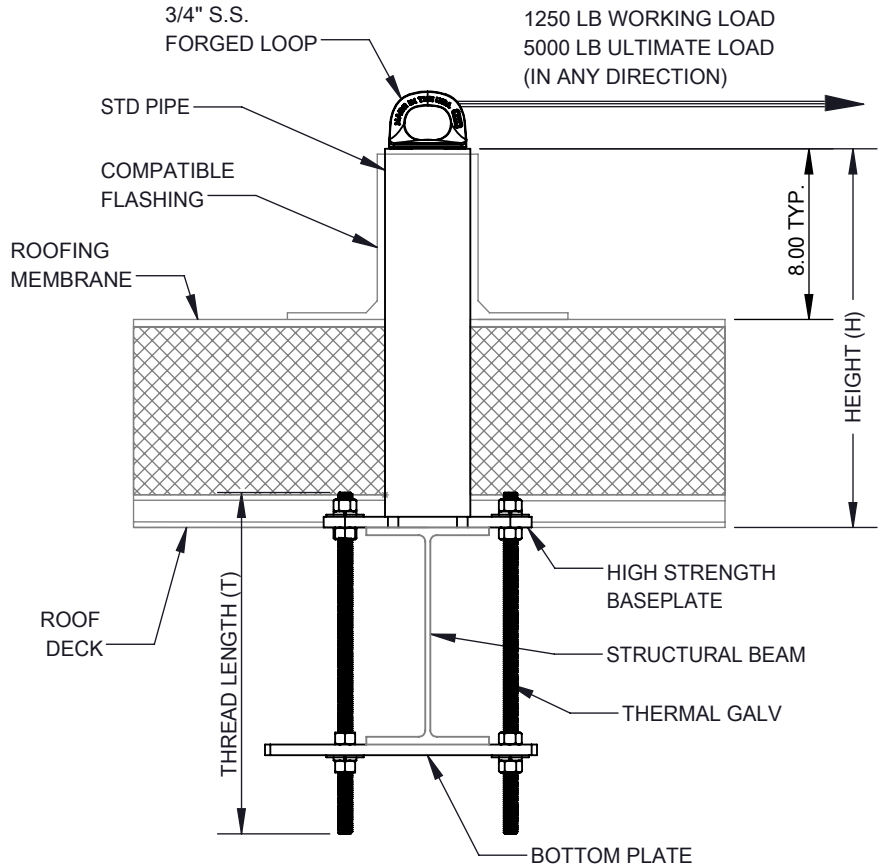
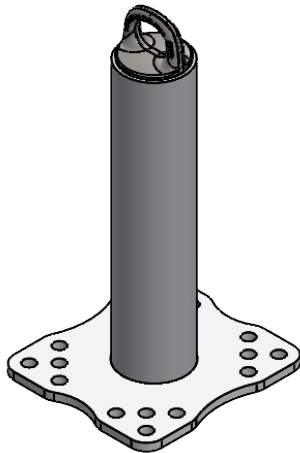

INFORMATION

- This anchorage has been designed and lab tested to support a 5,000 lbs load without failure.
- Unit Weight: 30-40 lbs.
- It is recommended that the anchorage be located, installed and tested by a qualified individual as required by OSHA.
- Finish Coating: ThermaGalv, Hot Dip Galv, & Stainless Steel.
- Additional attachment options available (see next page).

AVAILABLE HEIGHTS	12" 15" 18" 21" 24"
-------------------	---------------------

SECTION VIEW - FORGED LOOP ANCHORAGE

MATERIALS

- Hollow structural sections are ASTM-A500 Grade B.
- Flat plates are high strength structural quality carbon steel.
- Loop is forged 316 stainless steel.
- Bolts are Grade 2 with compatible nuts and washers.

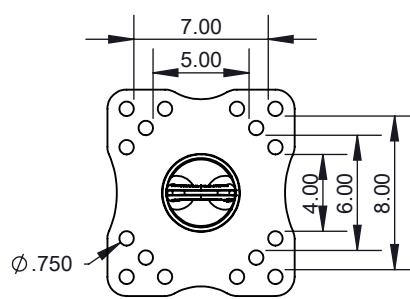

X1 BASEPLATE

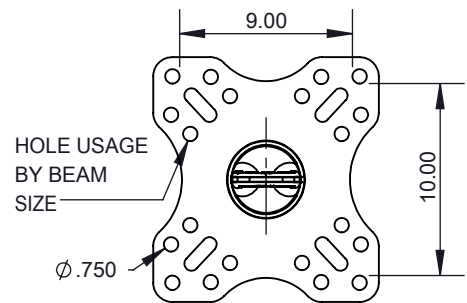

X2 BASEPLATE

The designed working load of the rooftop anchorage is 1,250 lbs and has been designed and tested to ensure that it can support a 5,000 lbs ultimate load and a 6,500 lbf arrest load as required in Z359.6.3.2.1.4. The product provided has been designed, fabricated and tested to withstand the OSHA recommended 5,000 lbs load. Any intended use of the product or its connection has not been verified by Rooftop Anchor, Inc. but should be analyzed by a licensed engineer or person qualified to make such analysis. The operator of this equipment is responsible to be trained in the correct usage and maintenance of this equipment by a competent person.

PROPRIETARY AND CONFIDENTIAL

The information contained in this drawing is the sole property of Rooftop Anchor, Inc.
 Any reproduction in part or as a whole without written permission of Rooftop Anchor, Inc. is prohibited.

BEAM WRAP ANCHORAGE - CONNECTIONS

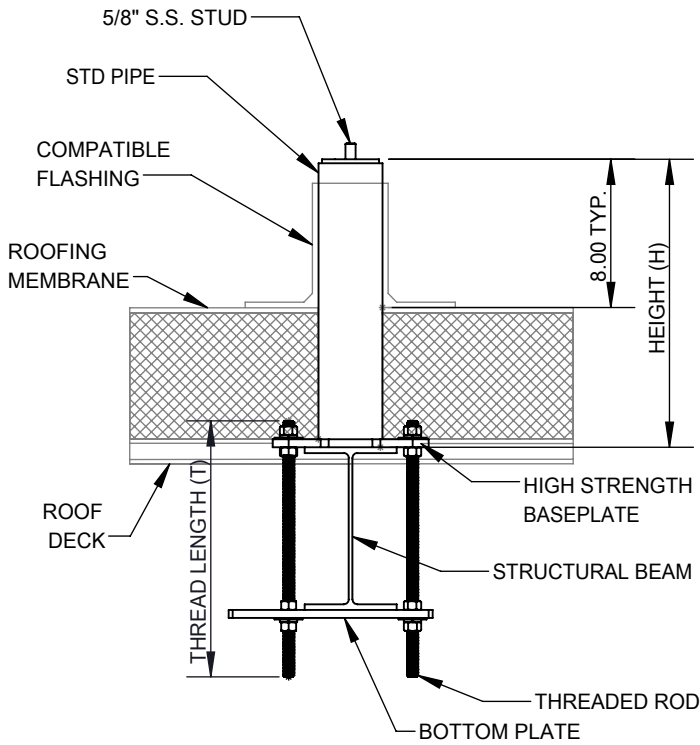

SECTION VIEW - STUD ANCHORAGE

MATERIALS

- Stud is ASTM F593C coarse threaded bolt.

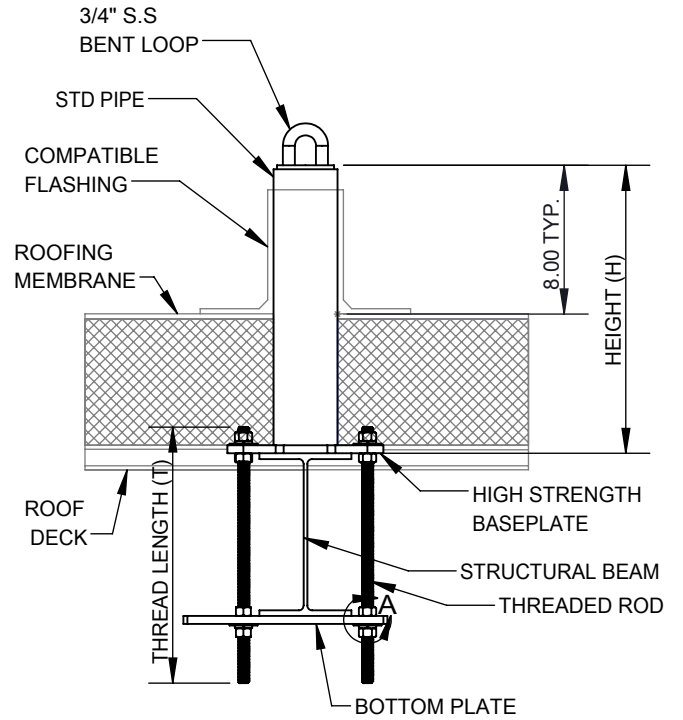

SECTION VIEW - BENT LOOP ANCHORAGE

MATERIALS

- Bent loop is 304/304L stainless steel.

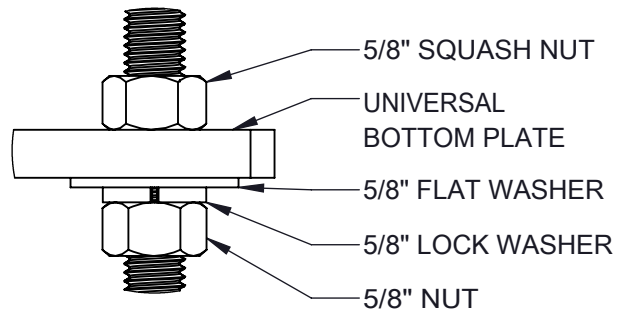

DETAIL A
SCALE 1 : 2

PROPRIETARY AND CONFIDENTIAL

The information contained in this drawing is the sole property of Rooftop Anchor, Inc.
Any reproduction in part or as a whole without written permission of Rooftop Anchor, Inc. is prohibited.