

TECHNICAL DATA SHEET

WELDED CONCRETE FIXED GUARDRAIL SYSTEM

GFW _ _

SECTOR
SAFETY SYSTEMS

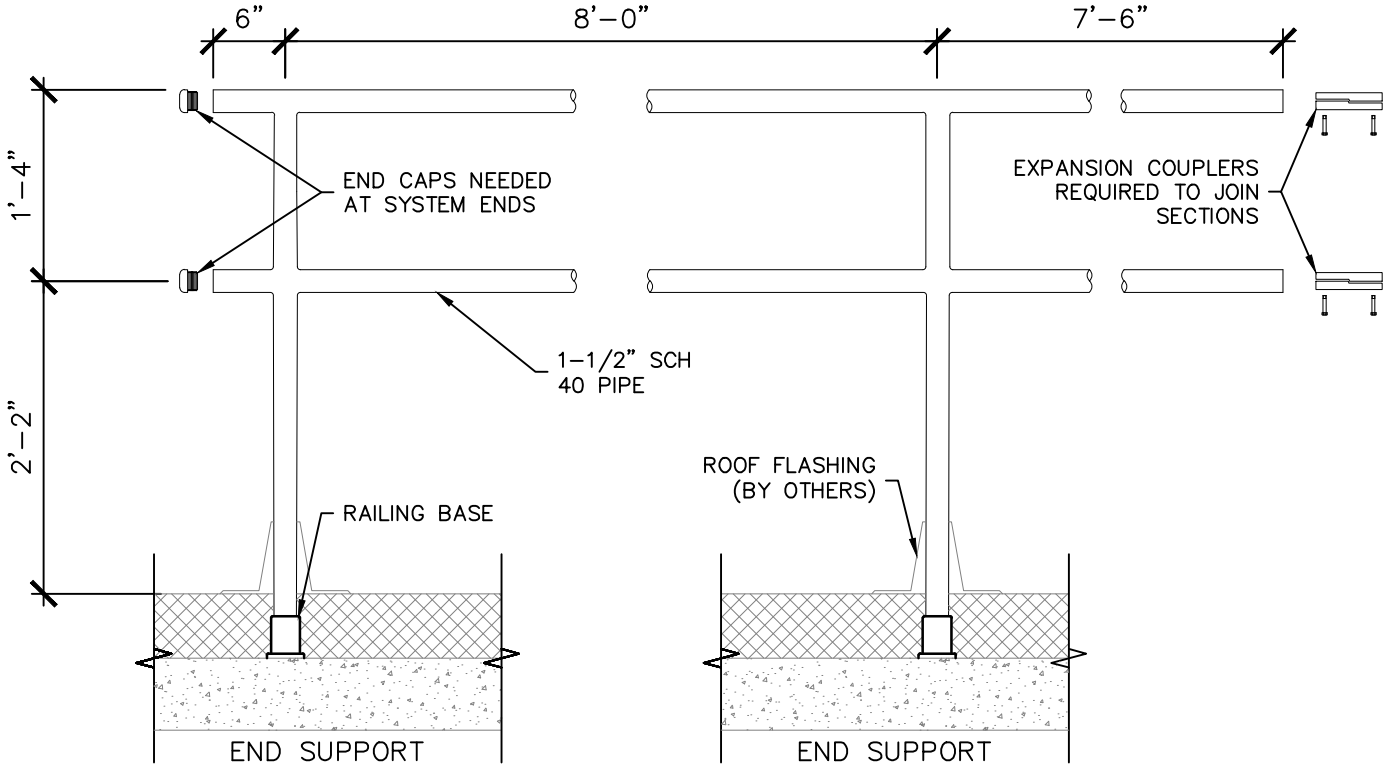

PART # GFW _ _

G]	PRODUCT TYPE (GUARDRAIL)
F]	ATTACHMENT METHOD (CONCRETE FIXED)
W]	GUARDRAIL STYLE (WELDED)
4]	VERTICAL HEIGHT: _" (42")
2]	
8]	RAIL LENGTH: _' _" (8' 0")
0]	

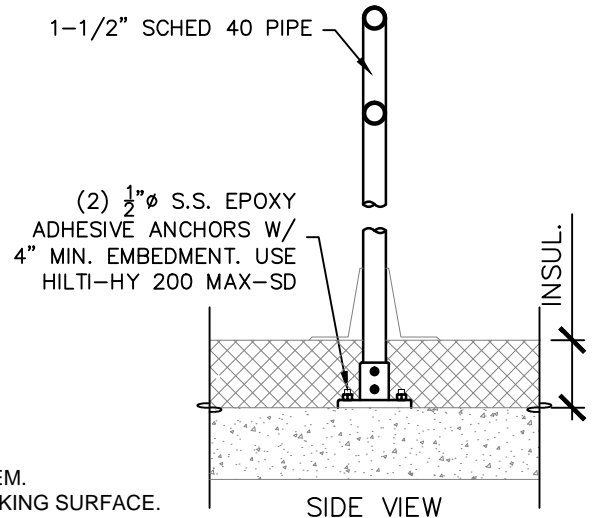

NOTES:

- ALL GUARDRAIL SHALL BE A PART OF AN OSHA COMPLIANT GUARDRAIL SYSTEM.
- GUARDRAIL SHALL HAVE A MINIMUM HEIGHT OF 42" ABOVE THE FINISHED WALKING SURFACE.
- PIPE RAILINGS SHALL HAVE A MINIMUM NOMINAL DIAMETER OF 1 1/2".
- POST SPACING SHALL NOT EXCEED 8'-0".
- ANCHORING OF POSTS AND FRAMING OF MEMBERS FOR RAILS SHALL BE SUCH THAT THE COMPLETED STRUCTURE SHALL BE CAPABLE OF WITHSTANDING A LOAD OF AT LEAST 200 POUNDS APPLIED IN ANY DIRECTION AT ANY POINT ON THE TOP RAIL.



PROPRIETARY AND CONFIDENTIAL
The information contained in this drawing is the sole property of Rooftop Anchor, Inc. Any reproduction in part or as a whole without written permission of Rooftop Anchor, Inc. is prohibited.

	PIPE	BRACKETS
MATERIAL	ASTM A53	CAST IRON, GALV.
QUALITY	100% VISUAL INSP.	100% VISUAL INSP.
COLOR	METALLIC	DULL METALLIC

